

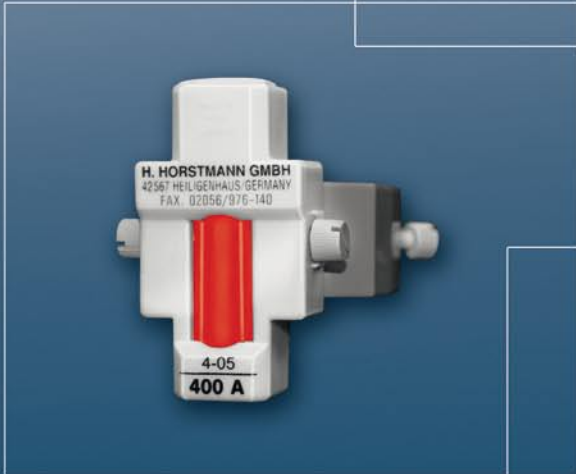

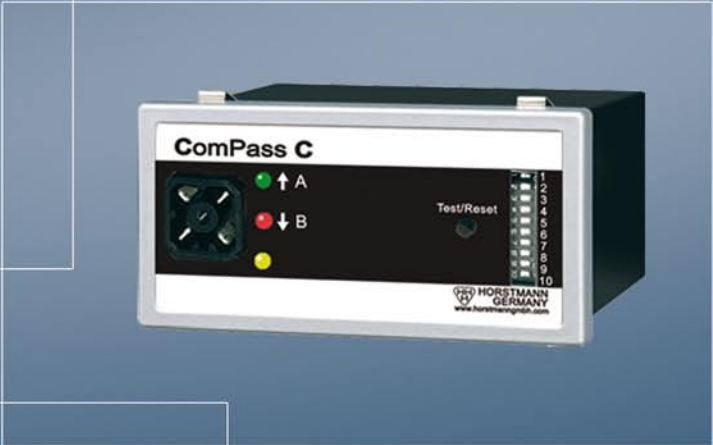











HORSTMANN GMBH



SHORT-CIRCUIT INDICATORS EARTH FAULT INDICATORS



	Short-Circuit Indicator Rotor Series	4
	Short-Circuit Indicator Fluid Series	5
	Short-Circuit Indicator OPTO-F 3.0, OPTO-F+E 3.0	6 – 8
	Short-Circuit Indicator SIGMA, SIGMA F+E Short-Circuit Indicator SIGMA plus	9 10
	Short-Circuit Indicator ALPHA	12 – 13
	Earth Fault Directional Indicator ComPass C	15
	Short-Circuit Indicator with Direction Decision RKA 1.1	16
	Earth Fault Indicator EARTH ZERO Earth Fault Indicator Brit 100.1, EARTH 2.0, EARTH 2.1, EARTH/M 2.0	17 18 – 19
	Earth Fault and Short-Circuit Indicator EKA-3	20 – 21
	Short-Circuit Indicator for Overhead Lines Navigator-LM Short-Circuit Indicator for Overhead Lines Navigator Radio	22 – 23 24 – 25
	Remote Indication via Mobile Communication	26 – 27

Short-Circuit Indicators are devices which are triggered by the magnetic field of a current conductor in the event of a short-circuit resulting in a tripped display.

Short-Circuit Indicators are mainly used for more efficient and quicker fault location in medium-voltage distribution networks. They can be installed on the current conductor / busbars, cables or overhead lines to be monitored. An optical display is tripped upon reaching or exceeding the rated trip current of the Short-Circuit Indicator.

Short-Circuit Indicators can be used either in radial or open ring operated networks.

Short-Circuit Indicators can also be used as Earth Fault Indicators provided that a single-phase current fault of sufficiently high level occurs in the defective conductor segment. In cases where low-level faults must be responded to, it is recommended to apply Short-Circuit Indicators using summation current transformers.

The fault is located between the last tripped indicator and the first non-tripped indicator (refer to the circuit diagram below).

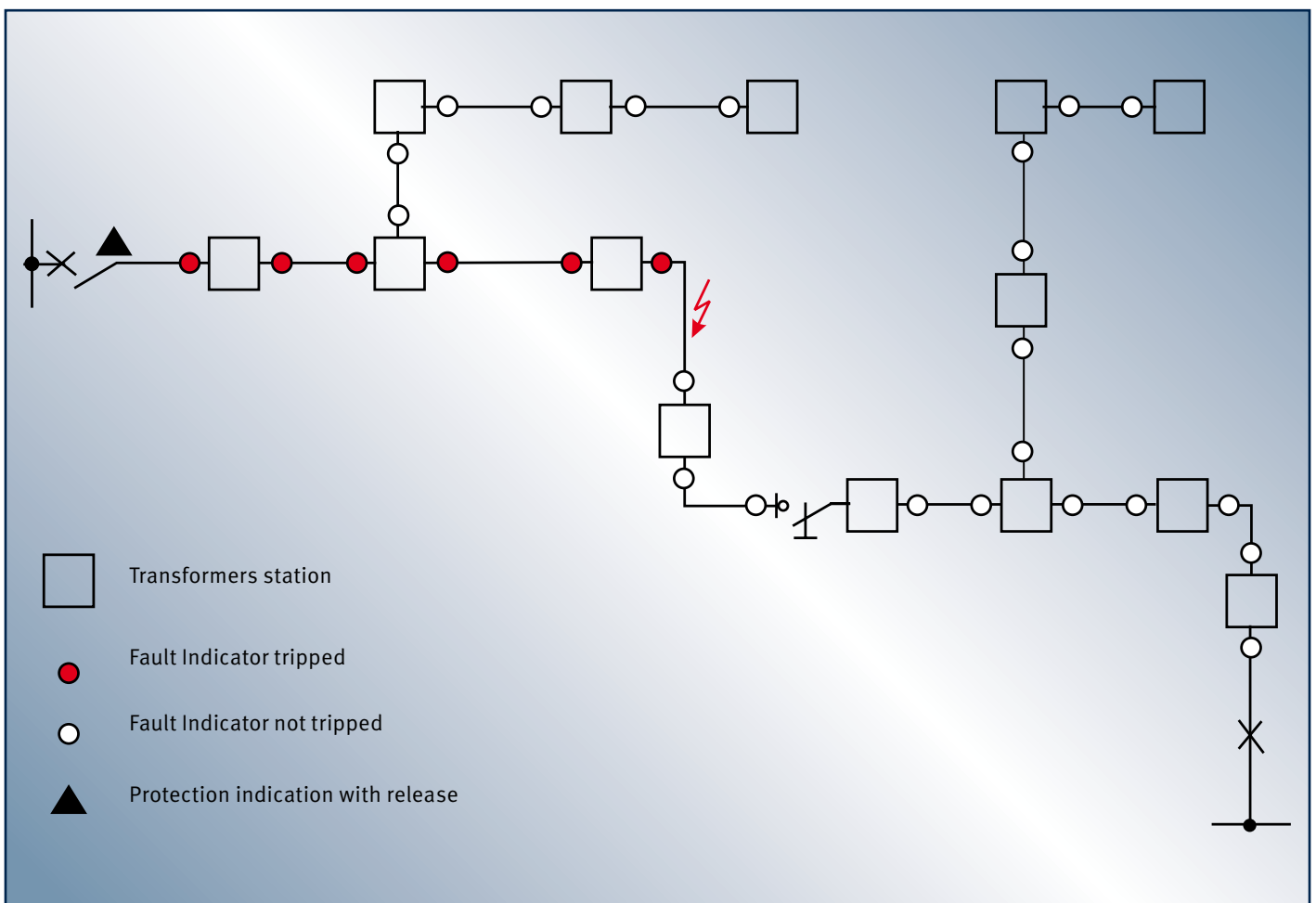

Short-Circuit Indicator Rotor Series

- Mechanical
- Manual reset

Principle of operation

Every conductor through which an electric current is flowing is surrounded by a magnetic field. At currents higher than the trip current ($\geq I$ trip current) a magnetic field strength H is induced sufficient to overcome the retaining force of a stop spring moving the rotor to the tripped position.

The reset of this indication has to be done after viewing with a hot stick.

Design

The illustration to the right shows a typical Short-Circuit Indicator with rotor assembly. It consists of a yoke (1) which is attached to the indication unit (2). The pivoted rotor (3), with reset pin (4) is painted two colours, red/black, one for 'tripped' and one for 'non-tripped' indication. Red indicates always the 'tripped' condition.

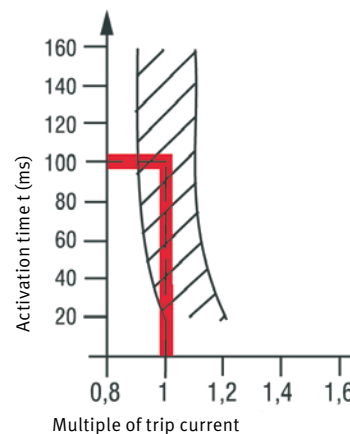
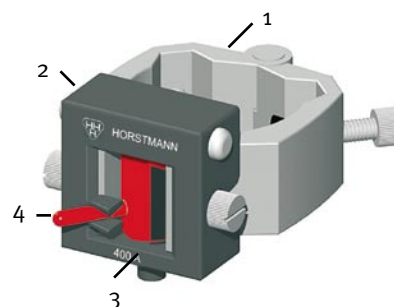
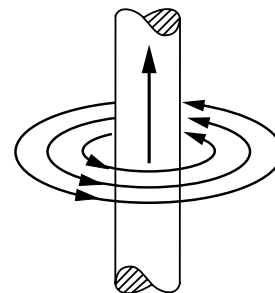

Technical Data	
Trip current	Optional factory set trip levels (between approx. 150 A and 2000 A)
Accuracy	$\pm 10\%$
Response time	100 ms \triangleq 5 full waves upon trip level
Material	Housing and fixing screws of polyamide. Yoke made of sintered metal, powder-coated.
Dimensions of display unit	40 x 40 x 18 mm

Order No.	I_{min}	for \varnothing mm
20-0101-001	150 A	8-16
20-0102-001	200 A	16-20
20-0103-001	200 A	20-30
20-0104-001	200 A	30-40
20-0105-001	200 A	40-50
20-0106-001	300 A	50-60
20-0108-001	300 A	60-80

Order No.	I_{min}	for <input type="text"/>
20-0120-001	200 A	30 x 4 - 40 x 10
20-0121-001	300 A	45 x 4 - 60 x 12
20-0122-001	150 A	20 x 4 - 25 x 6
20-0123-001	150 A	25 x 4 - 30 x 6

Order No.	I_{min}	for <input type="text"/>
20-0110-001	200 A	30 x 4 - 40 x 15

Installation instructions

If mounting on a single-conductor plastic-insulated cable, pass earth wire back to the protective ground through the yoke of the Short-Circuit Indicator.

All Short-Circuit Indicators are suitable for subsequent mounting by easily removing the indication unit from the yoke.

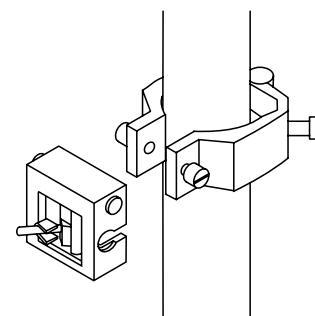
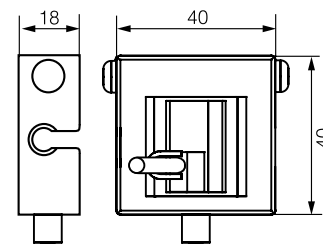

Short-Circuit Indicator Fluid Series

- Mechanical
- Automatic reset

Design

A sealed off glass tube contains a mixer, a liquid solution and coloured particles. The glass tube is accommodated in a plastic housing which again is attached to a yoke.

Principle of operation

When a short-circuit occurs, the mixer is pulled up by the magnetic field stirring up red particles in a clear liquid solution.

The coloured particles remain in suspension in the fluid for approximately 6 to 8 hours indicating a short-circuit.

Due to the gravity the coloured particles settle to the bottom within this time leaving a clear solution and indicating no fault (automatic reset).

Technical Data	
Trip current	400, 600 or 1000 A $\pm 20\%$
Response time	200 ms (100 ms also available on request)
Resetting	by time: approx. 6 to 8 hours
Temperature range	-40° C to +85° C

(max. continuous current at which tripping does not take place: approx. 0.5 times the response current)

Order No.	I_{min}	for ϕ mm
20-0401-000	400 A	8-16
20-0402-000	400 A	16-20
20-0403-000	400 A	20-30
20-0404-000	400 A	30-40
20-0405-000	600 A	40-50
20-0406-000	600 A	50-60
20-0408-000	1000 A	60-80

Order No.	I_{min}	for <input type="text"/>
20-0420-000	400 A	30 X 4 - 40 X 10
20-0421-000	600 A	45 X 4 - 60 X 12
20-0422-000	400 A	20 X 4 - 25 X 6
20-0423-000	400 A	25 X 4 - 30 X 6

Order No.	I_{min}	for <input type="text"/>
20-0410-000	400 A	30 X 4 - 40 X 15

Installation

Due to its principle of operation, this Short-Circuit Indicator must be mounted vertically (company name located at the top, max. deviation from vertical line 15 degrees)

Prior to installation, shake the indication unit vigorously to migrate the colour particles which have settled to the glass bottom.

If mounting on a single-conductor plastic-insulated cable, pass earth wire back to the protective ground through the yoke of the Short-Circuit Indicator.

All Short-Circuit Indicators are suitable for subsequent mounting by easily removing the indication unit from the yoke.

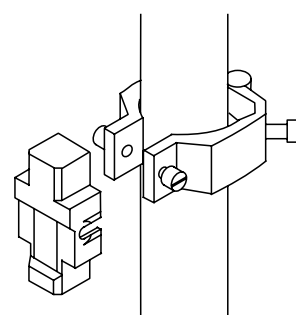
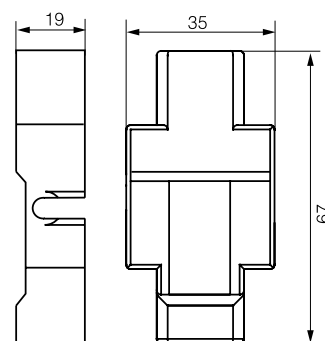
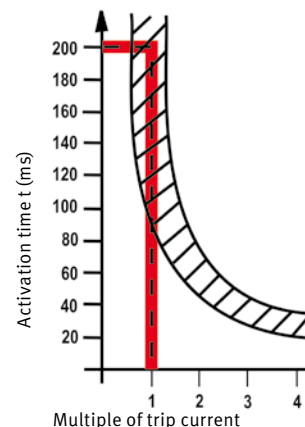
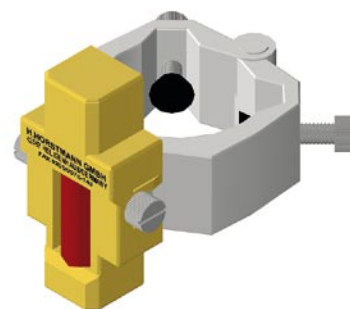
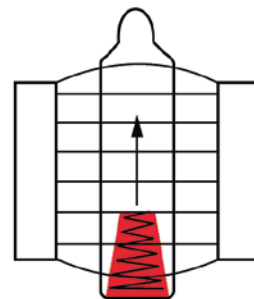

Short-Circuit Indicator OPTO-F 3.0

Short-Circuit and Earth Fault Indicator OPTO-F+E-3.0

- For radial and open ring networks
- Bright LED indication
- Automatic reset
- Potential separation over FOC
- SCADA-contact

The Short-Circuit Indicator OPTO-F 3.0 is designed to detect and indicate short-circuits on a three-phase cable-system. This indicator can be mounted either within encapsulated or in open type medium voltage power distributions. The signal transfer via fibre optic cables (FOC) ensures an electrical isolation between the short-circuit detection on the conductor/bar and the display unit.

The Short-Circuit Indicator Opto-F 3.0 may be used in radial and open ring operated networks. Unlike conventional Short-Circuit Indicators, the Opto-F 3.0 can also be used in closed ring networks with automatic reclosing function (ARC / RAR).

Design

The indication consists of the following components:

- 1 display unit accommodating the evaluation and indication electronics, a remote signal relay and the power supply
- 3 current transformers for the detection of short-circuits on each phase
- OPTO-F+E 3.0 only:
 - 1 current transformer for the detection of the earth fault (unbalance current of the 3-phase system)
- 1 conductor configuration consisting of three fibre optic cables

The Short-Circuit Indicator is available either installed in a panel mount plug-in housing or add-on housing.

Functional description

When a short-circuit occurs (phase to phase short-circuit), the current transformers that are fitted to each of the phases, emit light signals via fibre optic cables towards the evaluation unit incorporated in a housing where they are indicated as short-circuits by phase-selectively operated red flashing LEDs.

A single triggering (radial network) causes the LEDs to flash phase-selectively in the following rhythm: flash-flash.

A second triggering (ring networks with ARC / RAR) causes the LEDs to flash phase-selectively in the following rhythm: flash-flash / pause / flash-flash.

The indication is either reset automatically by passage of a preset time (e.g. of 4 hours), manually via test button or by remote reset contact. The automatic reset by the restoration of external auxiliary voltage is available as an option. The standard design of the device provides for power supply either by incorporated lithium cell, or by external DC or AC voltage. All devices are equipped with a relay for remote indication.

Additional feature for the OPTO-F+E 3.0:

In case of an earth fault, the summation current transformer meters and senses the unbalance (asymmetric) current of a 3-phase network and indicates it by a yellow LED.

Order No.	
33-0513-001	OPTO-F 3.0 Plug-in housing with 3 FOC-inputs and 3 LEDs
33-0613-001	OPTO-F 3.0 Add-on housing with 3 FOC-inputs and 3 LEDs
36-0323-001	OPTO-F+E 3.0 Plug-in housing with 4 FOC-inputs and 4 LEDs
36-0313-001	OPTO-F+E 3.0 Add-on housing with 4 FOC-inputs and 4 LEDs

For order numbers relating to current transformers please refer to page 8.
For order numbers relating to accessories please refer to page 14.



Plug-in housing



Add-on housing

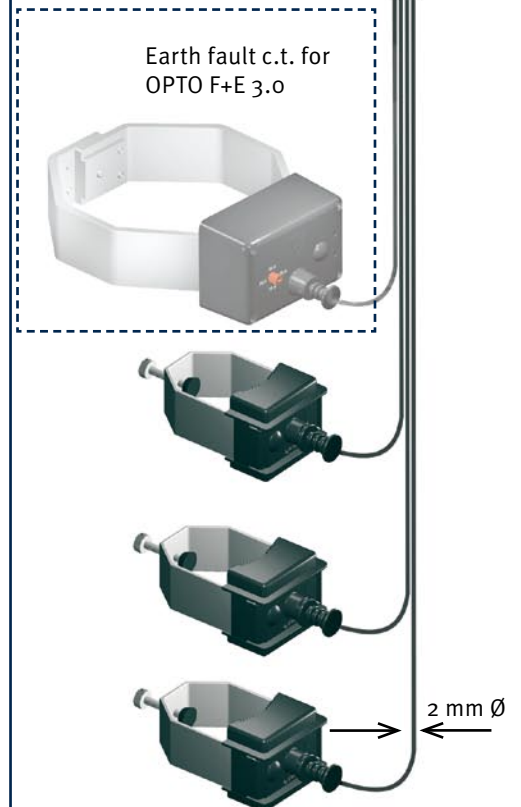

Short-Circuit Indicator OPTO-F 3.0

Short-Circuit and Earth Fault Indicator OPTO-F+E 3.0

- Plug-in and add-on housing

Technical Data	
Trip current short-circuit I_k	400, 600, 800 or 1000 A (adjustable)
Response delay t_{IK}	40, 60, 80, 100, 200, 300 or 500 ms (adjustable)
Trip current earth fault I_o (OPTO-F+E 3.0 only)	10, 20, 40 or 80 A or respectively 40, 80, 120 or 160 A (adjustable)
Response time t_{Io} (OPTO-F+E 3.0 only)	60, 100 or 200 ms (adjustable)
Accuracy	±15 %
Indication	3 red LEDs (phase-selective short-circuit), flashing period 2 s, double-flash sequence of 0.3 s with flashing period of 3 s OPTO-F+E 3.0 only: 1 yellow LED (earth fault)
External remote indication	LED signal lamp (option)
Relay contact	Potential-free relay contact (NO) for short-circuit indication (and earth fault indication for OPTO-F+E 3.0), permanent contact or momentary contact (adjustable via DIP switch) Contact capacity: 5 A / 380 V AC / 1250 VA max 5 A / 220 V DC / 150 W max
Resetting	Reset after passage of 1, 2, 4 or 8 h (adjustable via DIP switch)
Remote reset / Remote test	Separate inputs, potential-free NO contact Pulse time ≥ 0.5 s
Reset by voltage	Reset by return of voltage or by presence of external voltage supply ≥ 10 s (to be activated via DIP switch)
Power supply	1. Long-life lithium battery, operating life > 1000 h 2. 12 to 110 V DC ±10 % or 24 to 60 V AC, 50 to 60 Hz, ±10 % 0.3 VA Optional available: 115 to 230 V AC with optional transformer for DIN rail assembly (accessories)
Housing	Made of polycarbonate IP 65 (surface-mounted housing for panel mounting) IP 40 (plug-in housing), attachment with 4 inserted spring clips
Dimensions	Add-on housing: 101 x 139 x 45 mm (W x H x D) Plug-in housing: Installation dimensions: recommended cut-out according to DIN 92 ^{+0.8} x 45 ^{+0.6} mm External dimensions: 96 x 48 x 96 mm (W x H x D)
Operating temperature	-30° C to +70° C
Connections	1. Opto input terminals for FOC made of plastic, Ø 2.2 mm 2. Relay contact I_k (and I_o with OPTO-F+E 3.0) 3. Remote test and remote reset 4. External signal lamp (option) 5. AC / DC supply

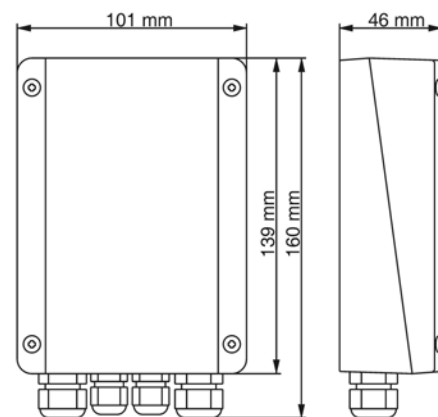

Add-on housing

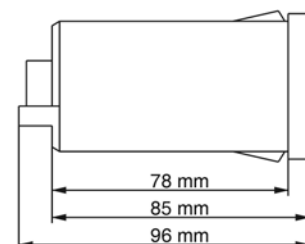
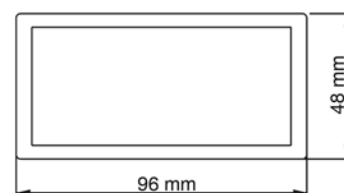

Plug-in housing

Recommended cut-out:
92^{+0.8} x 45^{+0.6} mm (IEC 61554)

Current transformers for Short-Circuit Indicators

Current transformers for Short-Circuit and Earth Fault Indicators

- Type OPTO-F 3.0
- Type OPTO-F+E 3.0

Current transformers for short-circuit detection

The current transformer for the detection of short-circuits is provided with integrated sensing of the trip threshold value. Once a preset trip level has been reached or exceeded, light pulse are emitted and transmitted from the medium-voltage cell via a fibre optic cable.

The current transformer can be mounted either directly on the medium-voltage cable or on the bright copper bar. Yokes of various dimensions are available (see below table).

The response levels of the current transformer can be adjusted by the customer (refer to order data).

Order No.	For conductor d2 Ø mm	Response value (±20 %) adjustable
49-0101-202	22-42 mm	400, 600, 800 or 1000 A
49-0101-203	40-60 mm	400, 600, 800 or 1000 A
49-0101-206	20 x 4 - 40 x 10 mm	400, 600, 800 or 1000 A

Further yoke sizes are available on request.

Current transformer for earth fault detection (OPTO F+E 3.0 only)

The current transformer for earth fault detection is a summation current transformer with integrated sensing of the trip threshold value. Once the preset trip level has been reached or exceeded, light pulses are emitted and transmitted from the medium-voltage cell via a fibre optic cable. The current transformer is dimensioned that it can be mounted around all three phases of the network. Due to the measurement principle, the earth fault indication is not qualified for compensated networks.

Order No.	For conductor Ø mm	Response value (±20 %) adjustable
49-6014-009	Up to 115 mm	40, 80, 120 or 160 A
49-6014-007	Up to 115 mm	(10), (20), 40 or 80 A
49-6014-022	280 x 50 mm (oval) For cables in the connection compartment of SF ₆ gas-insulated switchgears	80, 120, 160 or 200 A
49-6014-021	350 x 50 mm (oval) For cables in the connection com- partment of air-insulated switchgears	80, 120, 160 or 200 A

Further factory settings of response values are available.

Assembly instruction

If mounting on single-phase plastic-insulated cable pass the earth cable back to the grounding through the yoke of the current transformer. The current transformers feature subsequent mounting.

Fibre optic cables

The signal is transmitted from the current transformer to the display unit via fibre optic cable (FOC). Each FOC is ended with a plug connector on one extremity and a clean cut on the other extremity. Various FOC lengths (up to 10 m) are available. Standard lengths are 3 and 4 m.

Order No.	Cable length
49-0602-009	3 m (standard length for short-circuit current transformers)
49-0602-001	4 m (standard length for earth fault current transformers)

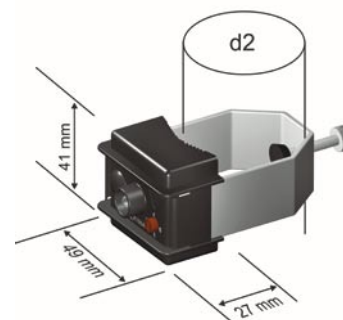

Mounting



Short-Circuit Indicator SIGMA

- Ultra bright LED display
- Self-adjustable or fixed setting trip current ratings

The SIGMA device is a Short-Circuit Indicator. It is used as remote indicator and serves to detect and display short-circuits in medium-voltage distribution networks. It consists of a display unit accommodated in a plug-in housing for panel mounting. The display unit is connected via measuring leads to three current transformers with current sensing function.

The SIGMA F+E device is a combined Earth Fault and Short-Circuit Indicator. Due to its principle of measuring, the Earth Fault Indicator is suitable for earth fault indication in networks with low-impedance or neutral point connection.

If the phase current exceeds either the preset response value for the duration of the programmed response time or the previously flowing operating current by a defined factor (load-dependent self-adjustment) the fault-affected phase will be indicated by an ultra-bright LED flashlight and a relay contact will be activated. If a second tripping occurs within a preset time, for example when automatic re-closing is in process, this condition will be indicated by a double-flashing LED. Reset occurs automatically by preset time passage, by closing an externally connected contact or manually via button. Moreover, a function test can be carried out either via the button or an external contact.

The current transformer type is provided with factory setting. The same current transformers as used for the ALPHA series can be taken. The trip current, the response delay, the time reset period and the kind of relay contact (permanent or momentary contact) can be selected via switches on the front face of the display unit.

Technical Data	
Trip current short-circuit (I_k)	(100), 200, 300, 400, 600, 800 or 1000 A fixed setting or self-adjustable. Self-adjustment in relation to the operating current (I_B): $I_B < 100 \text{ A} / I_k = 400 \text{ A}$, $I_B > 100 \text{ A} / I_k = 4 \times I_B$, $I_{k \max} = 1000 \text{ A}$
Response time (t_k)	40 ms oder 80 ms delay time
Trip current Earth fault (I_e)	20, 40, 60, 80, 100, 120 or 160 A
Response time (t_e)	80 or 160 ms delay time
Resetting	by time: 1, 2, 4 or 8 h
Remote setting and remote resetting	Via external momentary contacts
Temperature range	-30° C to +70° C
Power supply	Long-life lithium battery, expected shelf life ≥ 20 years, > 1000 h total flashing time
Relay contact	Permanent or momentary contact (1 s) 230 V AC / 1.0 A / 62.5 VA 220 V DC / 1.0 A / 30 W (max)

Order No.	
37-1111-002	SIGMA (plug-in housing)
37-1511-001	SIGMA (add-on housing)
37-1121-002	SIGMA, AC/DC (plug-in housing, with external power supply)
37-1521-001	SIGMA, AC/DC (add-on housing, with external power supply)
37-2111-002	SIGMA F+E (plug-in housing)
37-2511-001	SIGMA F+E (add-on housing)
37-2121-002	SIGMA F+E, AC/DC (plug-in housing, with external power supply)
37-2521-001	SIGMA F+E, AC/DC (add-on housing, with external power supply)

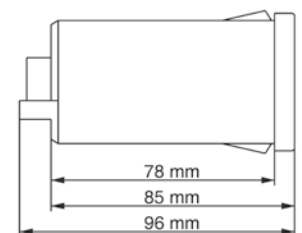
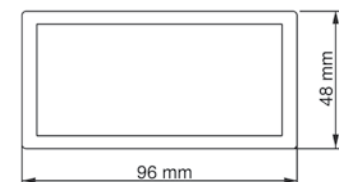

Plug-in housing

Recommended cut-out:
92^{+0,8} x 45^{+0,6} mm (IEC 61554)

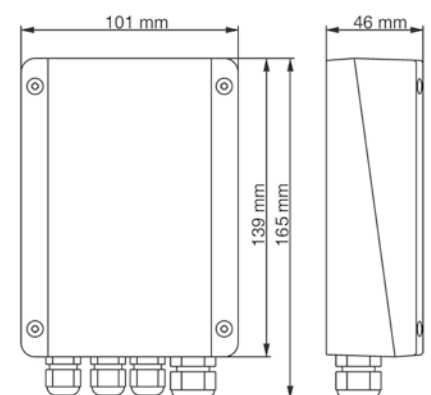

Add-on housing

For order numbers relating to current transformers please refer to page 11.
For order numbers relating to accessories please refer to page 14.

Short-Circuit Indicator SIGMA *plus*, SIGMA Ampere

- Adjustable to Horstmann-CTs

SIGMA *plus*

Besides the functions and advantages of the SIGMA and SIGMA F+E devices, the SIGMA *plus* offers the following features:

Selection switch which serves to adjust the device to the respective current transformers belonging to the Horstmann delivery spectrum for the ALPHA, DELTA, GAMMA and SIGMA series.

Special functions are available on customer's demand.

The principal purpose of the SIGMA *plus* is to carry out an indicator change and to replace old devices having reached or exceeded their service life by new ones - WITHOUT THE NECESSITY OF REMOVING THE ALREADY EXISTING CURRENT TRANSFORMERS IN THE SWITCHGEAR!

The SIGMA *plus* can be used both as Short-Circuit Indicator and as combined Short-Circuit and Earth Fault Indicator. The combined Short-Circuit and Earth Fault Indicator uses a summation current transformer instead of the Short-Circuit current transformer for L2.

Order No.	
37-3110-001	SIGMA <i>plus</i> (plug-in housing)
37-3510-001	SIGMA <i>plus</i> (add-on housing)
37-3120-001	SIGMA <i>plus</i> , AC/DC (plug-in housing, with external power supply)
37-3520-001	SIGMA <i>plus</i> , AC/DC (add-on housing, with external power supply)

For order numbers relating to current transformers please refer to page 11.
For order numbers relating to accessories please refer to page 14.

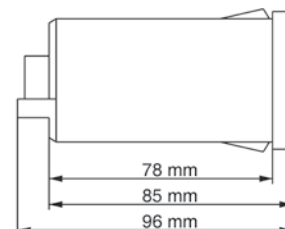
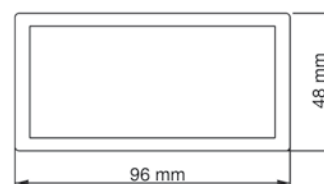

Plug-in housing

Recommended cut-out:
 $92^{+0,8} \times 45^{+0,6}$ mm (IEC 61554)

Current transformers for Short-Circuit Indicators

Current transformers for Short-Circuit and Earth Fault Indicators

- Type SIGMA
- Type ALPHA

Short-circuit current transformers for installation on bushings.

ALPHA	SIGMA	SIGMA F+E	SIGMA plus	for RMU make	Type	Order No.
•	•	•	•	ABB	SAFERING, RGC, SAFEPLUS (3 m cable length)	49-6012-009
•	•			ABB	SAFERING, RGC, SAFEPLUS 1 set consisting of 3 ct with the following cable length: 0.89, 0.99 und 1.09 m	49-6012-015
•	•	•	•	AREVA	FBA, GLA, GMA (92 mm Ø)	49-6010-030
•	•	•	•	AREVA	FBX plug-in ct (for pole plate 3 mm)	49-6012-004
•	•	•	•	Driescher	MINEX, G.I.S.E.L.A. Plug-in ct	49-6012-007
•	•			EATON/Holec	SVS (44 mm Ø) 1 set consisting of 3 ct	49-6010-032
•	•			EATON/Holec	XIRIA (70 mm Ø) 1 set consisting of 3 ct	49-6010-048
•	•	•	•	Ormazabal/F&G	GA + GE (96 x 96 mm)	49-6010-011
•	•	•	•	Schneider Electric	RM6 (80 mm Ø)	49-6010-044
•	•	•	•	Siemens	8DJ, 8DH, SIMOSEC (95 mm Ø)	49-6010-052
•	•	•	•	Siemens	8DJH	49-6010-060

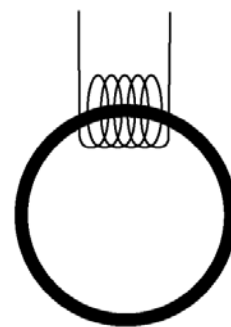

Current transformers for mounting on insulated cables

ALPHA	SIGMA	SIGMA F+E	SIGMA plus	Ø mm	Cable length	Order No.
•	•	•	•	15-52	3 m connecting cable	49-6011-040
•	•	•	•	15-52	6 m connecting cable	49-6011-043



49-6011-040

Current transformer for earth fault measurements

ALPHA	SIGMA	SIGMA F+E	SIGMA plus	Ø mm		Order No.
		•	•	40-115	Summation current transformer for mounting on cables	49-6013-016
		•	•	6-20	Earth fault current transformer for mounting on earth bar	49-6011-026
		•		350 x 50 oval	Earth fault current transformer for air-insulated switchgears	49-6013-027
		•		280 x 50 oval	Current transformers for SF6 gas-insulated switchgears	49-6013-028



49-6013-016



49-6013-027

Short-Circuit Indicator ALPHA M

- Flag-type indication
- Manual reset and test
- SCADA-contact

The Short-Circuit Indicator ALPHA M consists of a display unit in a plug-in housing for panel mount and three current transformers which are connected to the device via measuring leads.

The indication unit contains the electronic circuit, a miniature generator with turning knob, three flag-type indications, and a potential-free relay contact.

The indication is initiated by short-circuit and persists until it is reset by rapidly turning the turning knob to the left.

The Short-Circuit Indicator can be function-tested at any time by rapidly turning the rotary knob to the right.



Technical Data	
Trip current	400, 600, 800 or 1000 A (adjustable)
Response time	100 ms, no activation under 20 ms
Accuracy	±15 %
Indication	Three bi-stable display elements (black / red) for L1, L2, L3
Relay contact	Momentary contact ($t > 100$ ms) or alternatively permanent contact (adjustable via jumper) Contact data: 230 V AC / 1 A / 62.5 VA max 220 V DC / 1 A / 30 W max
Resetting	Manual
Housing	Polycarbonate Fixing by means of 4 integrated spring clips IP 40 (plug-in housing for panel mount)
Dimensions	Installation dimension: recommended DIN cut-out $92^{+0,8} \times 45^{+0,6}$ mm External dimension: 96 x 48 x 96 mm (H x W x D)
Operating temperature	-30° C to +70° C
Connections	12-pole terminal block, Wire cross section up to 2.5 sq.mm
Current transformer	Laminated transformer plates with coil <ul style="list-style-type: none"> • for mounting on bushings • for mounting on insulated cables

Order No.	
30-1815-001	ALPHA M

For order numbers relating to current transformers please refer to page 11.
For order numbers relating to accessories please refer to page 14.

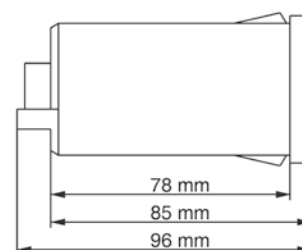
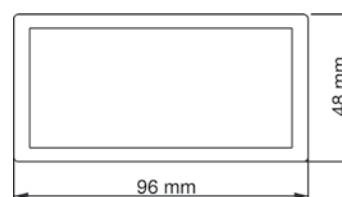

Recommended cut-out:
 $92^{+0,8} \times 45^{+0,6}$ mm (IEC 61554)

Short-Circuit Indicator ALPHA E

- Flag-type indication
- Testfunction
- Automatic Reset
- SCADA-contact

The ALPHA E Short Circuit indicator consists of a display unit in a plug-in housing for panel mount and three current transformers that are connected to the indication device via measurement leads. The display unit contains an electronic circuit, three flag-type indications, a potential-free relay contact, test and reset button. Once activated by the fault current, the display unit indicates for 2 or 4 hours and is then automatically reset. The device features premature remote reset by DC or AC (12 V - 60 V) or local reset by a push-button on the front face of the device.

A function test of the indicator can be carried out via push-button.

The energy to trigger the flags and the relay contact is provided by the fault current; the built-in lithium cell, which has a life expectancy of 15 years, is needed only for function testing and timed reset functions.



Technical Data	
Trip current	400, 600, 800 or 1000 A (adjustable)
Response time	100 ms, no activation under 20 ms
Accuracy	±15 %
Indication	Three bi-stable display elements (black / red) for L1, L2, L3
Relay contact	Momentary contact ($t > 100$ ms) or alternatively permanent contact (adjustable via jumper) Contact data: 230 V AC / 1 A / 62.5 VA max 220 V DC / 1 A / 30 W max
Resetting	<ul style="list-style-type: none"> • Automatic resetting: after 2 or 4 h (adjustable via jumper) • Manual reset • Remote reset: 12-60 V AC / DC ±10 %, at least 1 s
Housing	Polycarbonate Fixing by means of 4 integrated spring clips IP 40 (plug-in housing for panel mount)
Dimensions	Installation dimension: recommended DIN cut-out $92^{+0,8} \times 45^{+0,6}$ mm External dimension: 96 x 48 x 96 mm (H x W x D)
Operating temperature	-30° C to +70° C
Connections	10-pole terminal block, Wire cross section up to 2.5 sq.mm
Current transformer	Laminated transformer plates with coil <ul style="list-style-type: none"> • for mounting on bushings • for mounting on insulated cables

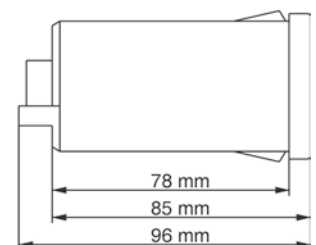
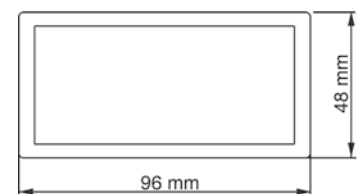

Recommended cut-out:
 $92^{+0,8} \times 45^{+0,6}$ mm (IEC 61554)

Order No.	
30-1715-001	ALPHA E

For order numbers relating to current transformers please refer to page 11.
For order numbers relating to accessories please refer to page 14.

OPTO	ALPHA	SIGMA	SIGMA F+E	SIGMA plus		Order-No.
•					Fibre optic cable 3 m (standard for short-circuit ct)	49-0602-009
•					Fibre optic cable 4 m (standard for earth fault ct)	49-0602-001
•					Cutting tool for fibre optic cable	49-0109-003
•					Transformer for power supply 115-230 V AC	49-0921-002
•	•	•	•	•	External indication lamp connection cable 5m	49-0702-005
•					Optical tester for tripping, fibre-optic connectable	49-0109-002
•	•	•	•	•	Disassembly clip for plug-in housing	040401-0008
•	•	•	•	•	Frame spring for front panel thidness 2mm	040804-0009
•	•	•	•	•	Frame spring for front panel thidness 2mm	040804-0010



Fibre optic cable



External indication lamp

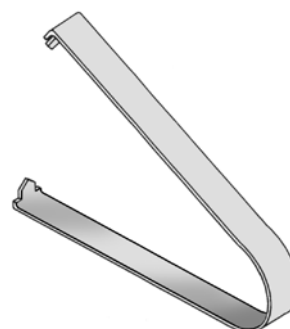

Disassembly clip

Earth Fault Directional Indicator ComPass C

The ComPass C is an earth fault directional indicator. This instrument is used as remote indicator with the ability to detect and display the respective direction of fault current flow in medium-voltage distribution networks.

The directional earth fault indicator consists of a display unit that is accommodated in a plug-in housing for panel mount, a summation current transformer or more specifically three single-phase current transformers, and a connection cable to be linked to a voltage interface.

The detection of the fault direction is based on an algorithm that evaluates the 50 Hz components of zero sequence current and voltage and can be used in compensated and isolated networks.

The unit is powered from a lithium battery. As an optional extra this instrument is available with an external power supply (24 to 240 V AC/DC).

The red LED lights up to indicate that an earth fault is detected in the forward direction of the line. The green LED indicates a fault in the reverse direction. The yellow LED is used for battery control and testing purposes to provide information on the function status of the instrument.

The unit includes two inputs, one of which is used for external testing and the other one for external resetting.

The ComPass C has also two relay outputs. These two relays signal the earth fault in a direction-selective manner.

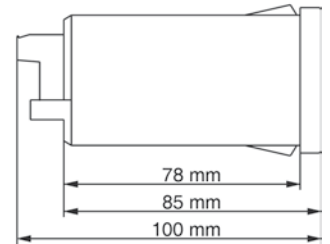
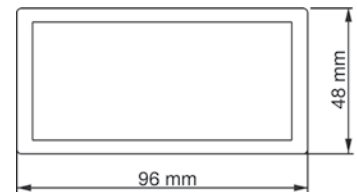
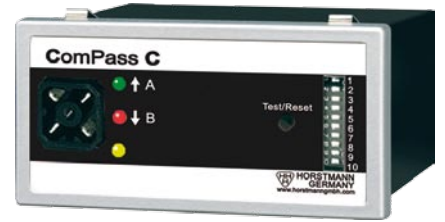

Recommended cut-out:
92^{+0,8} x 45^{+0,6} mm (IEC 61554)

Technical Data	
Detection method	Measurement of active current (cos φ method) or reactive current (sin φ method)
Trip current (insulated / compensated network)	2, 5, 10 or 20 A
Response time	60 or 240 ms
Resetting	By time after 1, 2, 4 oder 8h
Remote setting and resetting	via external momentary contacts
Operating temperature	-30° C to +70° C
Relay contact	Permanent or momentary contact (1s) NC and NO 230 V AC / 0,5 A / 30 VA 220 V DC / 1.0 A / 30 W (max.)
Power supply	Long-life lithium battery Life expectancy ≥ 20 years, Total flashing time > 3000 h External power supply: 24 - 240 V AC/DC (optional available)

Order No.	
38-1101-001	ComPass C
On Request	System-dependent interface cable

Current transformer

Order No.	
49-6023-000	∅ 40-105 mm (Summation current transformer)
49-6024-001	∅ 15-50 mm (Single-phase current transformer)



49-6023-000

Short-Circuit Indicator with Direction Decision RKA 1.1

- One-phase Short-Circuit Indicator for ring operated networks

The Short-Circuit Indicator RKA 1.1 is a water-proof encapsulated electronic indication device with yoke and display unit. The display unit contains the electronics, a long-life lithium battery and a light emitting diode (LED) with alternating colours. The ferro-magnetic yoke can be opened permitting the Short-Circuit Indicator to be attached subsequently to cables and leads already connected.

The Short-Circuit Indicator RKA 1.1 is of self-adjusting design. It constantly monitors the load current flowing through the conductor in relation to which it automatically adjusts its trip current. An instantaneous increase in current by more than 3 to 5 times the load current level provides a criterion for a fault current which is indicated by a flashing LED.

In case of a short-circuit, the LED flashes either red or green depending on the phase position of the first half wave of the detected short-circuit at the place of installation of the RKA 1.1 device. The visible colour does not give information on the direction of energy flow but merely on the direction of the current flow in the first half wave of the short-circuit. Thus, the fault must be pinpointed by local inspection of the substations in order to detect a change in colour (red/green) of each phase between the respective substations (see picture for explanation).



LED red/green indication

Technical Data	
Trip current	Min. 200 A / 100 ms $\pm 10\%$ at 20° C self-adjustment
Trip factor	from 3 to 5
Response time	Adjustment delay: approx. 25 sec. Holding time: approx. 30 s
Indication	5 mm two-colour bright LED (red / green) Flashing frequency: 0.57 Hz (1.75 sec. periodically) Total indicating time: ≥ 800 hours
Rated voltage / frequency	≤ 46 kV, 50 Hz, 60 Hz as an option
Resetting	Manual resetting (by reset magnet available as an option) Automatic resetting: after 4 hours $\pm 20\%$ By restoration of the current (Order No. 40-3124-001): ≥ 5 A load, 60 sec. after the last excitation
Power supply	Non-replaceable lithium battery, 3 V, 1,2 Ah, Shelf life: approx. 20 years
Material	Housing: UV-resistant polycarbonate Yoke: steel
Weight	300 g
Cable diameter	22-40 mm
Operating temperature	-30° C to +70° C

Order No.	Reset
40-3124-001	Manual, time, current
40-3224-001	Manual, time

Short-circuit locating in a ring system

One-phase short-circuit

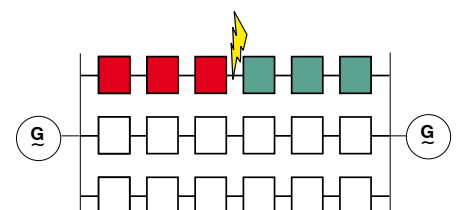

two-phase short-circuit

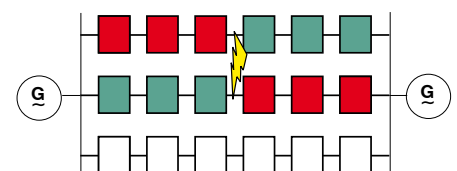

Earth Fault Indicator

EARTH ZERO

The Earth Fault Indicator, type EARTH ZERO, is applied to medium voltage underground distribution cable networks.

The unit is available in an add-on housing or alternatively in a plug-in housing. A current transformer for earth fault pick up of a max. diameter of 130 mm is offered.

Earth faults are indicated by a blinking red LED and an optional external lamp.

Technical Data	
Electrical Data	
Trip current	25, 50, 75 or 100 A selectable
Response time	80 or 160 ms, selectable
Accuracy	±10 % at 20° C
Current transformer	flexible core, Ø to 130 mm, cable length: 3m
Indication	1 blinking red LED in control unit
Total flashing time	≥1200 h
External voltage	110 to 240 V AC / 50 Hz Voltage reset by supply voltage for ≥10 sec
Resetting	Voltage resetting: 110 to 240 V AC/50Hz (max. indication time 24h), 2, 4 or 8 h, selectable Manually by test - button
Functional test	Manually by test - button
Relay contact	Change - over contact Permanent or momentary (1s), selectable Rating: 1 A / 250 V AC / 60 VA max., 0.5 A / 220 V DC / 30 W Additional semiconductor output for driving Horstmann external lamp
Power supply	Lithium battery, 3 V, 1.0 Ah, life expectancy: >15 years
Operating temperature range	-30° C to +70° C
EMI test standards	EN 61000-4-2 to EN 61000-4-5
Mechanical Data	
Wall-mounted housing	139 x 101 x 45mm (H x W x D), weight: approx. 260 g, IP65
Plug-In Housing	48 x 96 x 85mm (H x W x D), weight: approx. 120 g, IP40
External lamp (optional)	
Indication	1 blinking red LED in external lamp powered by central unit, cable length: 5 m
Total flashing time	≥ 500 h (EARTH ZERO with external lamp)

Order No.	
EARTH ZERO add-on housing	32-0503-001
EARTH ZERO plug-in housing	32-0513-001

Accessories	
Current transformer	49-6013-029
External lamp	49-0701-010 (5m)

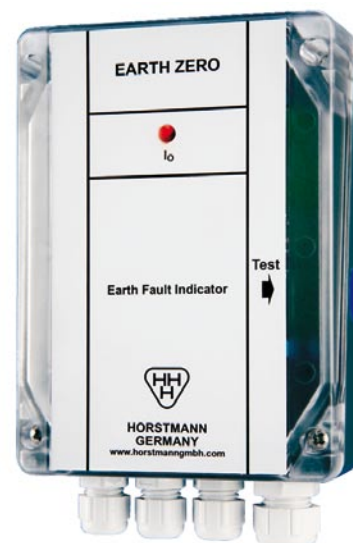

- fixed trip current
- external power supply
- voltage reset

The Earth Fault Indicator signals possible earth faults by means of a red flag if the asymmetrical current of a 3-core cable exceeds a pre-set trip current.

Description

The Earth Fault Indicator is a two-component instrument which consists of a current transformer and an indicating device. The current transformer consists of a split core formed by coated plates which bear an encapsulated coil. The core can be wound circularly around a conductor, up to an outside diameter of 90 mm, resp. 115 mm and fastened by cable tie. The c.t. is connected to the indicating device with a 3.0 m long cable (2 x 0.5 qmm). The housing of the indicating device is made of polycarbonate which is resistant to both ultra violet rays and weather conditions. It can be attached to any wall by means of four screws.

Application

The Earth Fault Indicator is used in conjunction with medium voltage networks, with single-sided feed, or in open ring main systems. Its current transformer is attached around the outer sheath of a three-phase conductor, in each ring main unit, to the incoming feeding cable or the outgoing cable. The indicating device is positioned in the installation in such a way that it can be easily read. In the event of an earth fault in a cable all the Earth Fault Indicators are tripped up to the faulty section, the equipment downstream of this point remains in the „non-indicated” setting. The faulty cable section is easily located by tracing out the last indicator that has been tripped and the first indicator which has not been tripped. The fault can be switched off and the rest of cable can be put into operation again.

BRIT 100.1



Trip current:	25 A
Response time:	<100 ms
Accuracy:	±10%
Current transformer:	diameter 90 mm resp. 115 mm
Time delay reset:	>10 s <30 s
Degree of protection:	IP65
Temperature range:	-25° C to 70° C
High current withstand:	20 kA/1 s
Material housing:	Polycarbonate, vandalism-proof
Yoke:	powder-coated ferrite
Relay contact:	./.
Electromagnetic compatibility:	yes
Power supply:	110 to 240 V AC
Resetting:	automatic by returning voltage

Terminal board:

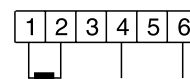

C.T. 110 to 240 V AC

Order-No.	
Indicating system	32-0102-003
Current transformer (cable length 3 m)	
dia. 40 - 90 mm	49-6013-004
dia. 60 - 115 mm	49-6013-006

Earth Fault Indicator

- 25A / 50A selectable
- external power supply
- voltage reset
- SCADA-contact

- 25 A / 50 A selectable
- manual reset

EARTH 2.0



EARTH 2.1



EARTH/M 2.0



<p>Trip current: 25 A / 50 A selectable</p> <p>Response time: <100 ms</p> <p>Accuracy: ±10%</p> <p>Current transformer: diameter 90 mm resp. 115 mm</p> <p>Time delay reset: >10 s <30 s</p> <p>Degree of protection: IP65 add-on housing IP40 plug-in housing</p> <p>Temperature range: -25° C to 70° C</p> <p>High current withstand: 20 kA / 200 ms</p> <p>Material housing: Polycarbonate, vandalism-proof</p> <p>Yoke: lacquered core lamination</p> <p>Relay contact: 125 V/2 A/30 W/60 VA max. t >100 ms</p> <p>Electromagnetic compatibility: yes</p> <p>Power supply: 110 to 240 V AC</p> <p>Resetting: automatic by returning voltage</p>	<p>25 A / 50 A selectable</p> <p><100 ms</p> <p>±10%</p> <p>diameter 90 mm resp. 115 mm</p> <p>>10 s <30 s</p> <p>IP65 add-on housing IP40 plug-in housing</p> <p>-25° C to 70° C</p> <p>20 kA / 200 ms</p> <p>Polycarbonate, vandalism-proof lacquered core lamination</p> <p>./.</p> <p>yes</p> <p>by fault current</p> <p>manual</p>
---	--

Terminal board:

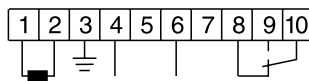

C.T. 110 to 240 V AC relay

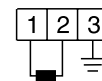

C.T.

Order-No.
 Indicating system
 Current transformer
 (cable length 3 m)
 dia. 40 - 90 mm
 dia. 60 - 115 mm

EARTH 2.0 32-0703-001
 EARTH 2.1 32-0703-002

 49-6013-015
 49-6013-016

32-0802-002

 49-6013-015
 49-6013-016

Earth Fault and Short-Circuit Indicator EKA-3

- LED indication, remote
- Rechargeable battery
- 3 trip settings for earth fault
- 1 trip setting for short-circuit
- Automatic reset / voltage reset

The Earth Fault and Short-Circuit Indicator is designed to indicate earth faults and short-circuits on a 3 phase cable system. The unit is mounted within switchgear and will indicate a fault condition when current is detected above present amperage trip ratings.

Description

The Fault Indicator consists of the following components:

- Indicating unit with rechargeable battery, indication and relay
- One large current transformer for monitoring three phases with a range of 50 mm to 90 mm
- Two small current transformers for short-circuit sensing on cables with a range of 20 mm to 50 mm
- External three LED indication lamp
- Connecting cables

External indication is achieved by mounting the unit flush with the switch gear panel. It is recommended to mount the unit near the top of the switch gear to promote easy visibility.

Application

The Fault Indicator is used in medium voltage networks (1-36 kV) with single-sided-feed or in open ring main systems. One current transformer is installed around the outer sheath of a three phase-cable. Two smaller current sensors are installed on the cables.

In the event of an overcurrent or fault, all the indicators are tripped and begin blinking from the feeder up to the faulted cable. All the indicators beyond this point remain in the non-indicating mode.

The faulted cable can be easily located by tracing the last indicator which has not been tripped. The faulted circuit can be sectionalized and repaired while the remaining circuit can be put back in service. The sensitivity for indicating an earth fault can be selected for three ratings 40 A, 80 A or 160 A by means of a selector switch, which is provided inside the unit. The switch is accessible after removing the front panel. The setting of the trip current is visually indicated by LEDs. The green LED means 40 A, the yellow LED means 80 A and the red LED means 160 A. The trip current for phase faults is set for a short-circuit current of 450 A (standard).

Method of operating

During the monitoring time the equipment is supplied with 230 V AC. The source is the main network.

During this time the integrated accumulators are charged. The “ready-for-operation” mode is indicated by means of a LED in the indicating unit which remains on. The external indicating lamp is off.

In the event that the current transformers sense an earth fault or short-circuit current, an alternating contact relay is activated after a time delay of 80 ms and the LED indicating lamp and the external indicating lamp blink at one-second cycles.

If the supply network switches-off within the following two seconds, then the voltage supply for the equipment is taken over by the batteries and the intermittent blinking of the indicating lamps continue to signal the fault for up to 14 hours. In the event that the main network does not switch-off within two seconds then the equipment reverts to the monitoring mode.



External indicating lamp



1-phase c.t.



3-phase c.t.

Earth Fault and Short-Circuit Indicator EKA-3

- LED indication, remote
- rechargeable battery
- 3 trip settings for earth fault
- 1 trip setting for short-circuit
- automatic reset / voltage reset

Re-setting subsequent to fault

After a fault, the equipment is reset automatically as soon as the voltage supply is re-established.

Testing

Testing is only possible, if the batteries have been charged or while the unit is supplied by the network. The indicating unit contains a green, yellow and a red LED and only one of these three LEDs lights-up at a time, the green LED indicates 40 A, the yellow 80 A and the red 160 A.

Technical data	
External power supply	230 V AC -20 % to +10 %
Internal power supply	4 NiMH rechargeable batteries
Trip current for earth fault	40, 80 and 160A selectable
Trip current for short-circuit	450 A (standard) 300, 600, 800 or 1000 A on request
Response time	80 ms
Temperature range	-20° C to +65° C
Accuracy	±10 %
Relay contact	250 V AC/DC, 30 W; 60 VA, momentary or permanent contact (selectable by jumper)
External Indicating lamp	3 LEDs, 1500 mcd
Capacity of rechargeable battery	Approx. 14 hours at 20° C
Resetting	By time: after approx. 14 hours By return of voltage: 220 V to 250 V AC

Order No.	
Indicator unit	
36-0205-001	Plug-in housing
36-0202-001	Add-on housing
Set of current transformers	
49-6011-045	2 CTs for Ø 15 - 50 mm 1 CT for Ø 50 - 90 mm
49-6011-048	2 CTs for Ø 15 - 50 mm 1 CT for Ø 90 - 115 mm
49-0701-002	External indicating lamp with 3 LEDs, 3 m cable length

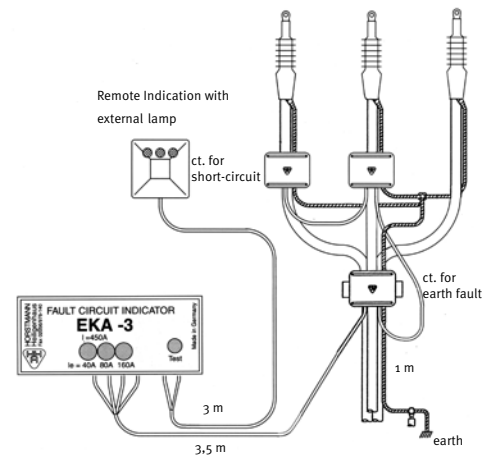

Mounting, schematical

Short-Circuit Indicator for Overhead Lines Navigator-LM

- Load-dependend self-adjustment
- Visible LED-indication
- Automatic battery control
- Automatic Reset

Description

The Navigator-LM Short-Circuit Indicator is an electronic device which is designed for medium-voltage utility overhead lines. It consists of a housing made from black UV-stable polyamide material with a stainless steel clamping mechanism, a transparent cap, a display unit with light emitting diodes, and an electronic circuit. The Short-Circuit Indicator is powered by replaceable long-life lithium batteries which have a life expectancy of 15 - 20 years. The display unit is provided with an integrated battery control. When the battery capacity decreases from a total indicating time of 400 hours to a residual time of 50 hours, the indicator will signal this condition via a flashing yellow indicator light for up to 6 months. The Short-Circuit Indicator is installed on and removed from overhead lines with a hot stick. The display unit provides excellent visibility from all sides.

Function

The Navigator-LM is provided with a load-dependent self-adjustment of the trip current, i. e. the indicator continuously samples the load current on the overhead line and electronically sets a corresponding trip point for a fault according to the load current. The maximum load current is kept in a 72 hour high load memory so that the indicator is most favourably adapted to the network to be monitored even if low load is present.

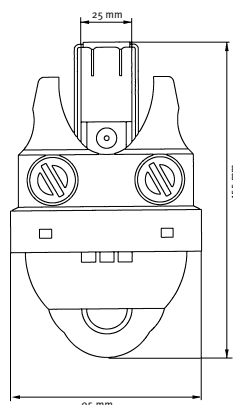

The Navigator-LM allows for differentiating between two subsequent short-circuit detections. The detection of the first short-circuit results in an equally flashing LED, whereas upon detecting a second short-circuit (e. g. after ARC) the LED is switched to double flashing.

Time /current characteristic Navigator LM

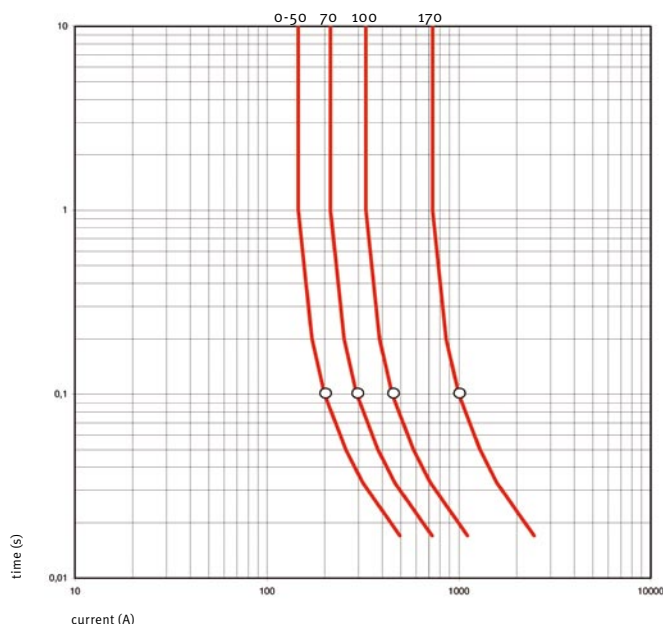

Load current [A]	0 - 50	70	100	170
Trip current [A] / 100 ms	200	294	450	1000



Special features of different types

Navigator-LM Version A

(Order No. 41-2101-111)
Indication by 6 high intensity LEDs. Automatic reset either by return of current or after passage of a preset time whichever occurs first, or manual reset.

Navigator-LM Version B

(Order No. 41-2101-211)
Indication by 6 high intensity LEDs. Automatic reset after passage of a preset time, or manual reset.

Navigator-LM Version C

(Order No. 41-2101-311)
Indication by 4 red LEDs and 2 high intensity yellow LEDs. Automatic reset of the red LEDs either by return of current or after passage of a preset time or manual reset. Automatic reset of the yellow LEDs exclusively after passing of a preset time or manual reset.

Navigator-LM Version E

(Order No. 41-2101-511)
The indicator samples the line current and the line voltage. Activation of indication is enabled under the condition that the line has been under voltage for at least 60 seconds. Reset 60 sec. after voltage recovery, after passage of the preset time or manual reset. Thus, high inrush currents, even after reclosure, are blocked for indication.

		A	B	C	E
Trip current, self-adjustment depending on load current	≥200 A / 100 ms (see current/time characteristic)	•	•	•	•
Temperature range	-30° C to +70° C (ANSI standard testing -40° C to +85° C)	•	•	•	•
Accuracy	±10 % at 20° C	•	•	•	•
Load tracking	Load current ≥50 A	•	•	•	•
Trip factor	4 – 6 times the load current (see current/time characteristic)	•	•	•	•
Adjusting delay	≥50 sec. load current flow period	•	•	•	•
Load memory for self-adjustment	72 hours	•	•	•	•
Indication	4 red LEDs (>5000 mcd respectively 7000 mLm each)	•	•	•	•
	2 yellow LEDs	•	•	•	•
Resetting	Resetting by return of current >3 A load current	•		•	
	Automatic reset by time, after passage of 4 hours ±10 % (optional 2 or 8 hours)	•	•	•	•
	Reset after restoration of voltage, line voltage, ≥5 kV				•
	Manual reset	•	•	•	•
Flashing frequency	30 per minute	•	•	•	•
Total indicating time	>400 hours	•	•	•	•
Power supply	2 lithium batterie packs replaceable, shelf life >15 years	•	•	•	•
Battery check	One yellow LED, flashing frequency: 6 per minute	•	•	•	•
Maximum operating voltage	≤46 kV /50 Hz or 60 Hz	•	•	•	•
Current withstand	25 kA / 200 ms	•	•	•	•
No influence to indicator by adjacent cables due to immunity	Horizontal conductor distance >250 mm	•	•	•	•
Cable diameter range	8 – 29 mm	•	•	•	•
Housing material	UV-stable polycarbonate / polyamide	•	•	•	•
Clamping mechanism	Stainless steel	•	•	•	•
Function test / reset	By means of a permanent magnet	•	•	•	•
Visibility	>50 m at daytime, >150 m at night / 360 degree visibility	•	•	•	•
Weight	470 g	•	•	•	•
Degree of protection	IP68	•	•	•	•
Order No.	Navigator LM	41-2101-111	41-2101-211	41-2101-311	41-2101-511
Order No.	Magnet (test and reset)	49-6001-002			
Order No.	Hot stick for installation with hook, 30 kV, 2 m long	65-0301-002			

Navigator-PM without self-adjustment and with fixed trip current (e.g. 800 A / 100 ms) ex factory after consultation available.

Short-Circuit Indicator for Overhead Lines Navigator-LM Radio

- Radio transmitter
- Control LED

The Navigator-LM Radio Short-Circuit Indicator for overhead lines is used for the detection and remote indication of short-circuits in medium-voltage overhead lines.

The Navigator-LM Radio works always in combination with a radio receiver which is mounted on the overhead line pole. Once a short-circuit has been detected, the Navigator emits a signal to the radio receiver via an incorporated transmitter. The radio signals are evaluated by the receiver and the resultant status including battery control is provided to the output contacts. Four different code configurations - A, B, C and D - can be adjusted. Permanent or momentary contact, battery monitoring as well as coding of the group message can be adjusted on the receiver.



Technical Data	
Trip current	100 A / 100 ms (without load tracking)
Accuracy	±10 % @ 20° C, ±20 % @ -20° C to +70° C
Load tracking	Load ≥30 A
Trip factor / trip delay	4 times the load / delay ≥50 s, level memory ≥72 h
Current resetting / Time resetting	≈3 A / 4 h ±20 %
Indication / flashing frequency	Red LED flashes every 2 s on excitation
Battery control	Yellow LED flashes every 10 s upon reaching 500 h active time
Function test	By means of a magnet that must be applied along the SET / RESET point
Total indicating time (flashing time)	> 700 hours
Power supply	2 replaceable lithium battery packs, approx. 15 years shelf life
High-voltage / frequency	≤46 kV / 50 Hz
Current withstand / Immunity against external field influence	25 kA effectiv @ 200 ms / 22 cm @ 10 kA
Cable diameter	8 – 29 mm
Temperatur range	-30° C to +75° C
Housing / installation	UV-stable polycarbonate / hot-stick application
Weight	480 g
Clamping mechanism	stainless steel
Radio transmission	Integrated antenna
Frequency / capacity / modulation / transmission	869,850 MHz ±25 kHz / 1 mW / FM / periodically every 1 to 1.6 s for 100 ms
Transmission range / Compa- tibility	>30 m / EN 300 220-3, EN 301 489-3 (EMV)
Coding	A, B, C and D, each with excitation and battery control
Order No.	
41-8101-111	Navigator-LM Radio Code A
41-8101-121	Navigator-LM Radio Code B
41-8101-131	Navigator-LM Radio Code C
41-8101-141	Navigator-LM Radio Code D
Associated facility	
28-7000-007	Radio Receiver with 6 relay outputs

Radio Receiver for Navigator Radio

- Radio receiver
- With relay outputs

The Radio Receiver processes and evaluates specific radio signals from the Navigator Radio and provides its tripping and reset condition as well as the battery status to five output contacts. The output for the battery status indicates an exhausted Navigator battery and remains closed until the DC supply at the receiver is shortly interrupted.

Four different Navigator code configurations - A, B, C and D - permit either a group or phase-selective message and are provided onto four dedicated outputs. The function of the signal contacts is previously defined by a built-in DIP switch. If adjusted to momentary contact function, the contact will close each time the corresponding Navigator Radio is tripped. If adjusted to permanent contact function, the contact remains closed for the whole active time of the corresponding Navigator Radio and is shortly opened upon new excitation of the Navigator Radio.

An external DC voltage supplies the receiver the status of which is signalled via a sixth output contact.

Technical Data	
Frequency/sensitivity/ bandwidth	869,850 MHz / - 100 dBm @ 50 Ω for 20 dB SINAD / 25 kHz
Receiver architecture	Quartz-controlled heterodyne receiver
Safety standard	EN 300 220-6
Range	>30 m
Temperature range	-20° C to +70° C
Power supply	12 V – 24 V DC ±10 %, 32 mA reception, 80 mA all outputs are active
Indication	Green LED for DC supply, internal red LED for valid reception
Outputs	A / B / C / D / LB (empty Navigator battery) / DC_OK
Contact data	350 V AC / 500 V DC / 0.5 A / max. 10 W
Message contacts	Momentary contact (250 ms, 6 s) or permanent contact (Navigator active time)
Connection	Internal terminals
Housing	Polycarbonate, degree of protection IP 65, integrated antenna
Installation	Pole or wall mounted
Dimension / Weight	138 (158) x 102 x 48 mm (L x W x H) / 0.5 kg

Order No.	
28-7000-007	Radio Receiver with 6 relay outputs



Remote Indications via Mobile Communication - Transmitter -

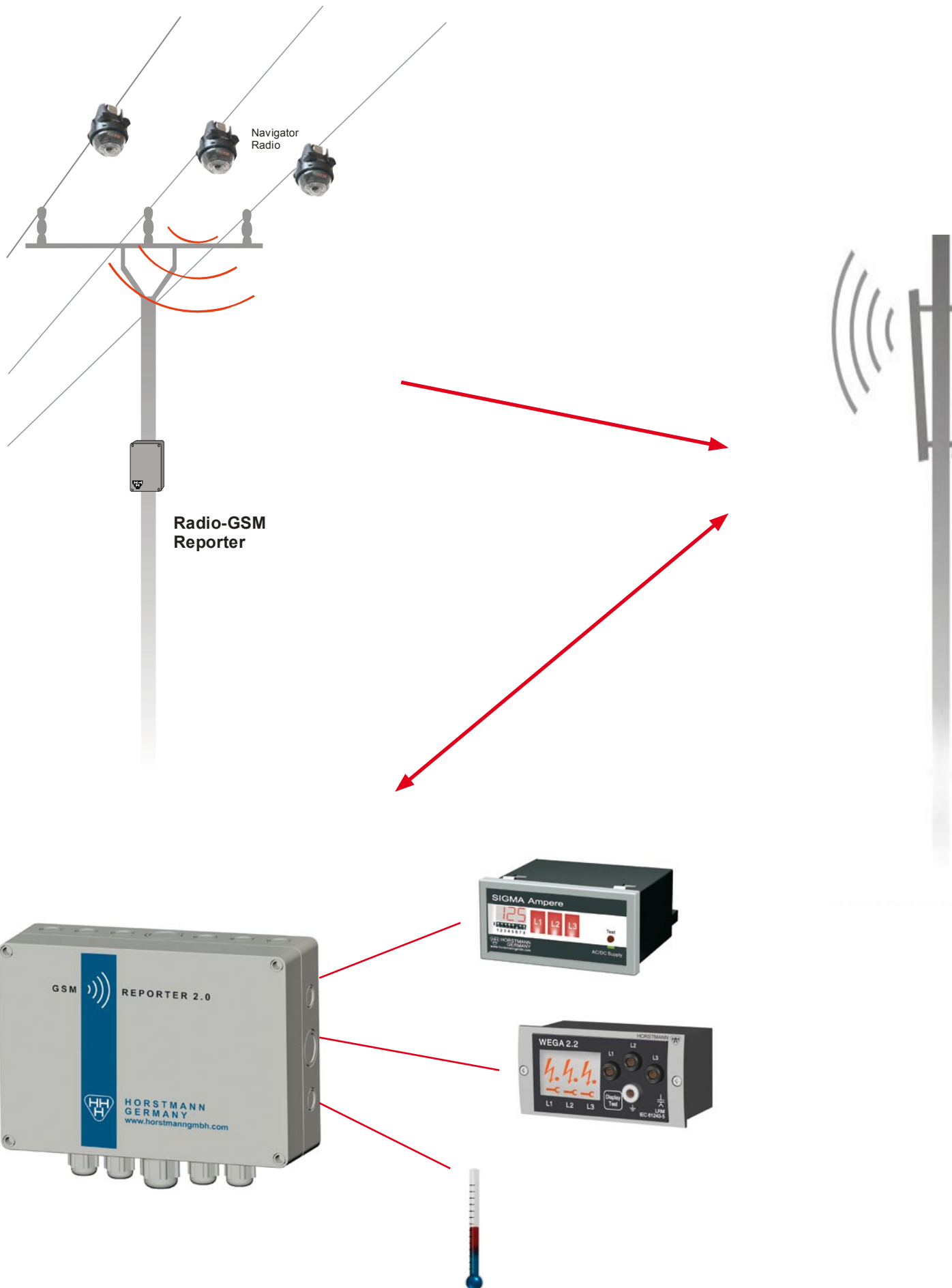

SMS-Functionality

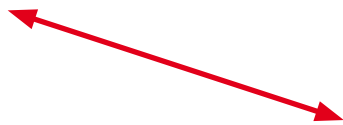

GSM-PORT/Relais

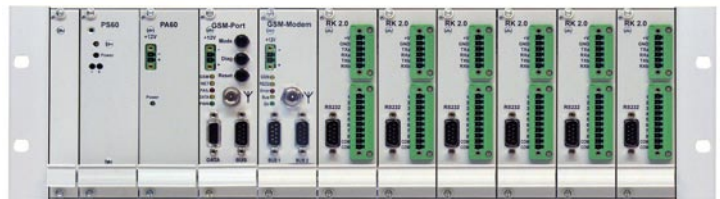

GSM-PORT/IEC





Dipl.-Ing. H. Horstmann GmbH · Heiligenhaus
Humboldtstr. 2 · 42579 Heiligenhaus · Germany
Tel.: 0049 (0)2056 976-0 · Fax: 0049 (0)2056 976-140
e.mail: info@horstmannmbh.com · www.horstmannmbh.com